

Select
Selects menu options and tunes channels

Power
Turns the DCT 2500 on and off

Menu
Displays the Main menu

Info
Displays current channel and program information

Guide
Displays the Electronic Program Guide

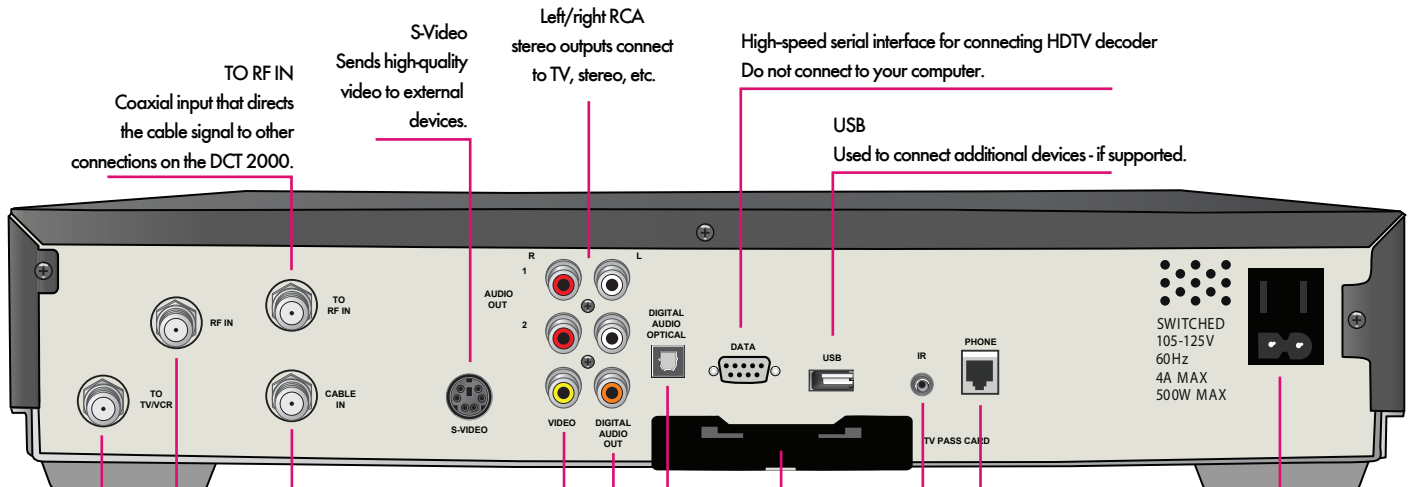

TO TV/VCR
Coaxial output to connect to the TV or VCR.

RF IN
Coaxial input that is connected to the TO RF IN.

Cable In
Coaxial input for incoming signal from the wall outlet.

RCA video output connects to an input on TV, DVD, etc.

Coaxial audio output to connect to a digital A/V receiver

Digital Audio Optical
Connects to a digital A/V receiver

This space is reserved for future use.

Phone
For use in Telco return systems. See user guide.

IR
A stereo miniphone connector connecting the optional Infrared (IR) Blaster attachment for your DCT 2000.

AC Power

User Guide

DCT2500 Digital Cable Receiver



MOTOROLA
intelligence everywhere™



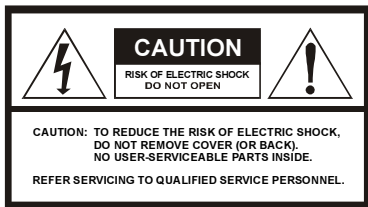

Graphical symbols and supplemental warning marking locations on bottom of terminal.

WARNING

TO PREVENT FIRE OR SHOCK HAZARD, DO NOT EXPOSE THIS APPLIANCE TO RAIN OR MOISTURE.

CAUTION

TO PREVENT ELECTRICAL SHOCK, DO NOT USE THIS (POLARIZED) PLUG WITH AN EXTENSION CORD, RECEPTACLE, OR OTHER OUTLET UNLESS THE BLADES CAN BE FULLY INSERTED TO PREVENT BLADE EXPOSURE.



The lightning flash with arrowhead symbol, within an equilateral triangle, is intended to alert the user to the presence of uninsulated "dangerous voltage" within the product's enclosure that may be of sufficient magnitude to constitute a risk of electric shock to persons.



The exclamation point, within an equilateral triangle, is intended to alert the user to the presence of important operating and maintenance (servicing) instructions in the literature accompanying the appliance.

This installation should be made by a qualified service person and should conform to all local codes.

REPAIRS

If you find the unit in need of repair, contact your cable system operator for repair or replacement.

NOTE TO CATV SYSTEM INSTALLER

This reminder is provided to call the CATV system installer's attention to Article 820-40 of the NEC that provides guidelines for proper grounding and, in particular, specifies that the cable ground shall be connected to the grounding system of the building, as close as possible to the point of cable entry as practical.

EXAMPLE OF ANTENNA GROUNDING

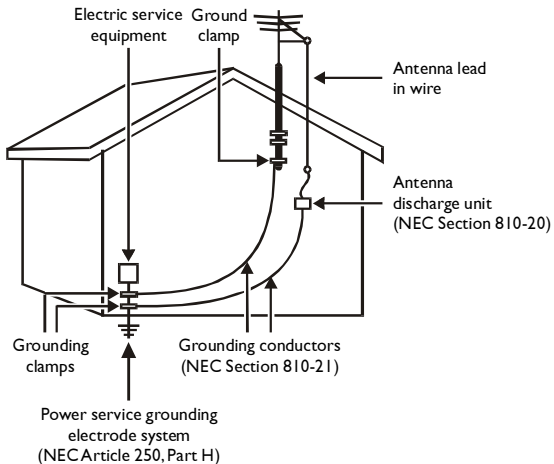

NEC=NATIONAL ELECTRICAL CODE

Important Safety Instructions

1 Read instructions

All the safety and operating instructions should be read before the appliance is operated.

2 Retain instructions

The safety and operating instructions should be retained for future reference.

3 Heed warnings

All warnings on the appliance and in the operating instructions should be adhered to.

4 Follow instructions

All operating and use instructions should be followed.

5 Cleaning

Unplug this product from the wall outlet before cleaning. Do not use liquid cleaners or aerosol cleaners. Use a damp cloth for cleaning.

6 Attachments

Do not use attachments not recommended as they may cause hazard.

7 Water and moisture

Do not use this equipment near water; for example, near a bath tub, wash bowl, kitchen sink, or laundry tub, in a wet basement, or near a swimming pool, and the like.

8 Accessories

Do not place this product on an unstable cart, stand, tripod, bracket, or table. The product may fall causing serious injury and serious damage to the appliance. Use only with a cart, stand, tripod, bracket, or table recommended by the manufacturer, or sold with the equipment. Any mounting of the appliance should follow the manufacturer's instructions, and should use a mounting accessory recommended by the manufacturer.

9 Ventilation

Slots and openings in the cabinet are provided for ventilation and to ensure reliable operation of the equipment and to protect it from overheating. The openings should never be blocked by placing the product on a bed, sofa, rug, or similar surface. Equipment should never be placed near or over a radiator or heat register, or in a built-in installation such as a bookcase or rack unless proper ventilation is provided.

10 Power sources

This product should be operated only from the type of power sources indicated on the marking label. If you are not sure of the type of power supplied to your home, consult your local power company. For equipment intended to operate from battery power, or other sources, refer to the operating instructions.

11 Ground or polarization

This equipment may be equipped with a polarized alternating-current line plug (a plug having one blade wider than the other). This plug will fit into the power outlet only one way. This is a safety feature. If you are unable to insert the plug fully into the outlet, try reversing the plug. If the plug should still fail to fit, contact your electrician to replace your obsolete outlet. Do not defeat the safety purpose of the polarized plug.

12 Alternate warnings

This equipment may be equipped with a 3-wire grounding-type plug, a plug having a third (grounding) pin. This pin will only fit into a grounding-type power outlet. This is a safety feature. If you are unable to insert the plug into the outlet, contact your electrician to replace your obsolete outlet. Do not defeat the safety purpose of the grounding-type plug.

13 Power cord protection

Power supply cords should be routed so that they are not likely to be walked on or pinched by items placed upon or against them, paying particular attention to cords at plugs, convenience receptacles, and the point where they exit from the appliance.

14 Outdoor Antenna Grounding

If an outside antenna or cable system is connected to the equipment, be sure the antenna or cable system is grounded as to provide some protection against voltage surges and built-up static charges.

15 Lightning

For added protection for this equipment during a lightning storm, or when it is left unattended and unused for long periods of time, unplug it from the wall outlet and disconnect the antenna or cable system. This will prevent damage to the video product due to lightning and power line surges.

16 Power lines

An outside antenna system should not be located in the vicinity of overhead power lines or where it can fall into such power lines or circuits. When installing an outside antenna system, extreme care should be taken to keep from touching such power lines or circuits, as contact with them may be fatal.

17 Overloading

Do not overload wall outlets and extension cords as this can result in a risk of fire or electrical shock.

18 Object and liquid entry

Never push objects of any kind into this equipment through openings as they may touch dangerous voltage points or short-out parts that could result in a fire or electrical shock. Never spill liquid of any kind on the product.

19 Servicing

Do not attempt to service this equipment yourself as opening or removing covers may expose you to dangerous voltage or other hazards, refer all servicing to qualified service personnel.

20 Damage requiring service

Unplug this equipment from the wall outlet and refer servicing to qualified service personnel under the following conditions:

- a** When the power supply cord or plug is damaged.
- b** If the equipment has been exposed to rain or water.
- c** If liquid has been spilled, or objects have fallen into the equipment.
- d** If the equipment does not operate normally by following the operating instructions. Adjust only those controls that are covered by the operating instructions as an improper adjustment of other controls may result in damage and will often require extensive work by a qualified technician to restore the equipment to its normal operation.
- e** If the equipment has been dropped or cabinet has been damaged.
- f** When the equipment exhibits a distinct change in performance, indicating a need for service.

21 Replacement parts

When replacement parts are required, be sure the service technician has used replacement parts specified by the manufacturer or have the same characteristics as the original part. Unauthorized substitutions may result in fire, electric shock, or other hazards.

22 Safety check

Upon completion of any service or repairs to this video product, ask the service technician to perform safety checks to determine that the product is in proper operational condition.

23 Heat

The product should be situated away from heat sources such as radiators, heat registers, stoves, or other products (including amplifiers) that produce heat.

24 Battery usage

Notwithstanding any information provided by Motorola in this manual regarding the use of batteries, the end user assumes all responsibility and liability to use and dispose of batteries in accordance with all applicable laws, rules and regulations. Motorola will not be liable to anyone for the end user's failure to use and/or dispose of batteries in the proper manner and in accordance with such laws, rules and regulations, or for any defect contained in batteries that may cause injury damage to persons or property.

25 Telephone equipment

Observe the following precautions when installing telephone modem equipment:

- a** Never install telephone wiring during a lightning storm.
- b** Never install telephone jacks in a wet location unless the jack is specifically designed for wet locations.
- c** Never touch uninsulated telephone wires or terminals unless the telephone lines have been disconnected at the network interface.
- d** Use caution when installing or modifying telephone lines.

Regulatory Information

Federal Communications Commission Radio and Television Interface Statement for a Class 'B' Device

This equipment has been tested and found to comply with the limits for a Class B digital device, pursuant to part 15 of the FCC Rules. These limits are designed to provide reasonable protection against harmful interference in the residential installation. This equipment generates, uses and can radiate radio frequency energy and, if not installed and used in accordance with the instructions, may cause harmful interference to radio communications. However, there is no guarantee that interference will not occur in a particular installation.

If the equipment does cause harmful interference to radio or television reception, which can be determined by turning the equipment off and on, the user is encouraged to try to correct the interference by one of the following measures:

- Increase the separation between the equipment and the affected receiver
- Connect the equipment on a circuit different from the one the receiver is on
- Ensure that the cover plate for the security card is secured and tight

Changes or modification not expressly approved by the party responsible for compliance could void the user's authority to operate the equipment.

Declaration of Conformity

According to 47 CFR, Parts 2 and 15 for Class B Personal Computers and Peripherals; and/or CPU Boards and Power Supplies used with Class B Personal Computers, Motorola, Inc., 6450 Sequence Drive, San Diego, CA 92121, 1-800-225-9446, declares under sole responsibility that the product identifies with 47 CFR Part 2 and 15 of the FCC Rules as a Class B digital device. Each product marketed is identical to the representative unit tested and founded to be compliant with the standards. Records maintained continue to reflect the equipment being produced can be expected to be within the variation accepted, due to quantity production and testing on a statistical basis as required by 47 CFR 2.909. Operation is subject to the following condition: This device must accept any interference received, including interference that may cause undesired operation. The above named party is responsible for ensuring that the equipment complies with the standards of 47 CFR, Paragraphs 15.107 to 15.109.

Canadian Compliance

This Class B digital apparatus meets all requirements of the Canadian Interference-Causing Equipment Regulations. Cet appareil numérique de la classe B respecte toutes les exigences du Règlement sur le matériel brouilleur du Canada.

Copyright © 2003 by Motorola, Inc. All rights reserved. No part of the contents of this book may be reproduced or transmitted in any form or by any means without written permission of the publisher.

MOTOROLA and the Stylized M Logo are registered in the US Patent & Trademark Office. Manufactured under license from Dolby Laboratories. "Dolby" and the double-D symbol are registered trademarks of Dolby Laboratories. All other product or service names are the property of their respective owners.

Motorola reserves the right to revise this publication and to make changes in content from time to time without obligation on the part of Motorola to provide notification of such revision or change. Motorola provides this guide without warranty of any kind, either implied or expressed, including, but not limited to, the implied warranties of merchantability and fitness for a particular purpose. Motorola may make improvements or changes in the product(s) described in this manual at any time.

CONTENT

Introduction	2
Front Panel.....	3
Rear Panel.....	6
Rear Panel Options.....	9
Recording Your Connections	11
Using the Remote Control	12
Installing Batteries	16
Basic Operation	17
Turning Power On and Off.....	17
Changing Channels.....	17
Adjusting the Volume.....	17
Electronic Program Guide.....	18
Audio Output Modes.....	18

Audio/Video Connections	19
Connecting your DCT2500	20
Standard TV Cabling	20
Standard VCR Cabling.....	21
Cabling with RF Bypass.....	22
Composite Baseband and S-Video.....	23
Composite VCR Cabling.....	24
Stereo Cabling Diagram (VCR to Stereo).....	25
Stereo Cabling Diagram (TV to Stereo)	26
Baseband Cabling Diagram	27
Dolby Digital Cabling Diagram	28
Troubleshooting	29

INTRODUCTION

Your DCT2500 includes one or more of the following features:

- Remote control
- Volume control
- Parental control
- Favorite channel recall
- Easy Pay-Per-View purchases
- Electronic program guide
- Video on Demand
- Digital audio

Congratulations on receiving your state-of-the-art DCT2500 digital consumer terminal. The DCT2500 brings unsurpassed digital audio and video quality to your TV viewing. Electronic program guide (EPG) menus provide convenient control of selecting and viewing programs. It's simple to set up and easy to operate.

You can purchase Pay-Per-View special events, recent movies or Video on Demand. Video on Demand is similar to renting a video, including the ability to pause, rewind, and fast-forward.

This guide introduces you to the features and operation of the DCT2500. Access to the DCT2500 features is gained through the EPG.

To get the most out of your DCT2500, be sure to read your EPG instruction manual.



INTRODUCTION

Front Panel

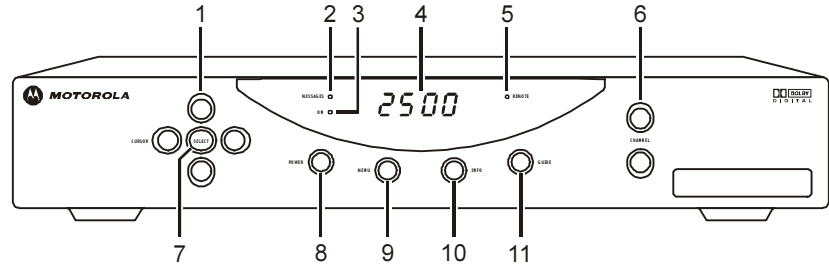



The DCT2500 front panel has 11 keys and an LED display. Use the keys to perform basic functions such as changing channels and powering on and off. Display the current channel or time of day on the LED by changing the default settings in the electronic program guide.



INTRODUCTION

Item	Description
1	Moves the cursor in menus and electronic program guide (EPG) screens
	
2	Lights to indicate that a message is present
MESSAGES ◊	
3	Lights when the unit is turned on
ON ◊	
4	Displays current channel number or time of day
2500	
5	Flashes when a signal is received from the remote control
◊ REMOTE	
6	Changes the channel up and down
	
7	Selects menu options, Pay-Per-View (PPV) events, and tunes channels from the EPG
	

INTRODUCTION

Item	Description
8	POWER  Turns the DCT2500 on and off
9	MENU  Displays the main menu
10	 INFO Displays current channel and program information
11	 GUIDE Displays the EPG

Rear Panel

Before you begin installing the DCT2500, take a moment to become familiar with the rear panel connections. These connectors are for system cabling. An AC power cord connects the DCT2500 to an electrical power outlet. For cabling diagrams, see *Connecting Your DCT2500*.

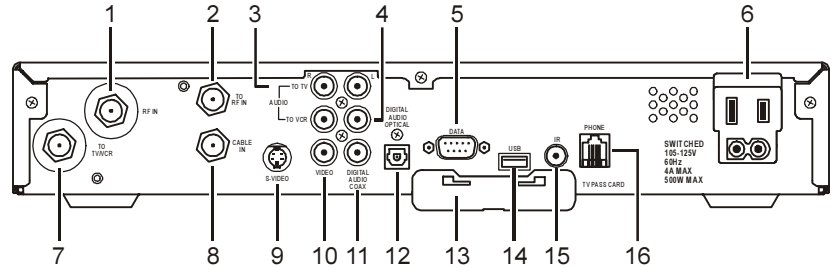

INTRODUCTION

Item	Description
1 RF IN	A coaxial input that is connected to the TO RF IN, see Connecting the DCT2500.
2 TO RF IN	A coaxial input that directs the cable signal to other connections on the DCT2500.
3 AUDIO OUT TO TV R L	Right/left RCA stereo outputs connect the DCT2500 to your TV. The audio output to your TV is volume controlled.
4 AUDIO OUT TO VCR R L	Right/left RCA stereo outputs connect the DCT2500 to your VCR. The audio output to your VCR is line level.
5 DATA	A high-speed serial interface for connecting an external high definition TV decoder (do not connect your PC to this interface).
6 AC power	This is a two-plug AC power inlet. The bottom plug is for attaching a power cord. The top plug can be configured for plugging in another device such as a TV or VCR.
7 TO TV/VCR	A coaxial output to connect the DCT2500 to the TV or VCR.
8 CABLE IN	A coaxial input for the incoming signal from the wall outlet.
9 S-VIDEO	An S-Video connector for sending high quality video to external devices (high-end VCR or TV) that accept S-Video. (Optional)
10 VIDEO	This RCA video output connects the DCT2500 to an input on a TV, VCR, or other device.

INTRODUCTION

	Item	Description
11	DIGITAL AUDIO COAX	A coaxial audio output to connect the DCT2500 to a digital A/V receiver.
12	DIGITAL AUDIO OPTICAL	A Toslink connector to connect the DCT2500 to a digital A/V receiver. (Optional)
13	TV Pass Card slot	This space is reserved for future use.
14	USB	The Universal Serial Bus (USB) is used to connect to devices such as keyboards, joysticks, scanners, disk storage, PCs, printers, and digital cameras, if supported. (Optional)
15	IR	A stereo mini-phone connector connecting the optional Infrared (IR) Blaster attachment for your DCT2500.
16	PHONE	For use in Telco return systems. See “Rear Panel Options” for more information. (Optional)

INTRODUCTION

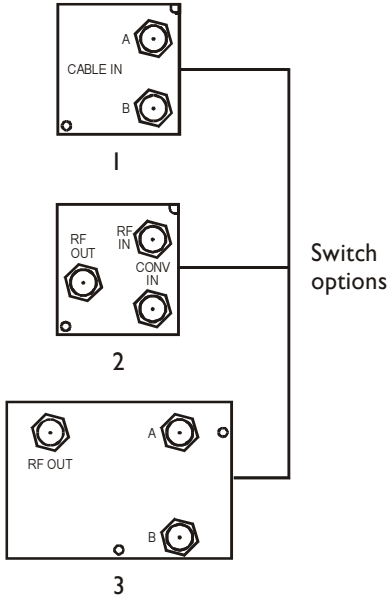

4

Telco
return

Rear Panel Options

The following rear panel options can be included on your DCT2500:

Item	Description
1 A/B Switch	This contains coaxial input connectors used in a dual cable system and with an A/B box.
2 RF Bypass	These coaxial connectors enable the cable signal to bypass the DCT2500 and go directly to a cable-ready TV or VCR.
3 DUAL A/B-RF BYPASS	These coaxial connectors are used in a dual cable system. The cable signal from A or B goes directly to a cable-ready TV or VCR.
4 Telco Return	The Telco Return Impulse Pay-Per-View option is a telephone connection module that enables you to purchase special programming on one-way cable systems.

INTRODUCTION



5



6



7

	Item	Description
5	USB	The Universal Serial Bus (USB) is used to support devices such as keyboards, joysticks, scanners, disk storage, PCs, printers, and digital cameras, if supported.
6	S-Video	The S-Video connector sends high quality video to external devices (high-end VCR or TV) that accept S-Video.
7	Toslink	The Toslink connector is used to connect the DCT2500 to a digital A/V receiver.

RECORDING YOUR CONNECTIONS

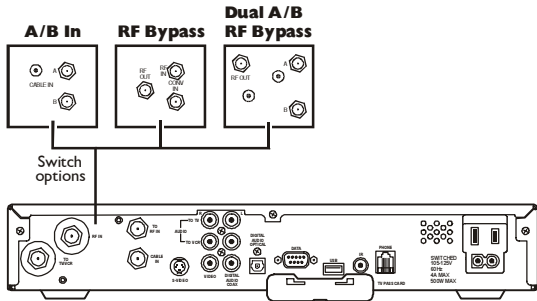

Use this diagram to record cable connections from the rear panel. Later you can use this diagram to reconnect your system if you move the equipment, or add new equipment.

Your home entertainment equipment may not have all connectors shown in the illustration or may have connectors that are not shown here.

Disconnect the power from the DCT2500 before connecting or changing cable connections. Do not place another component or object on top of the DCT2500.

Home Theater Receiver

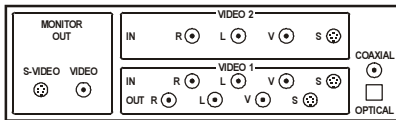

VCR

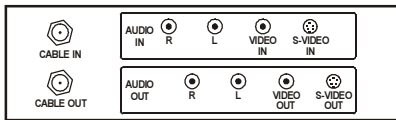

TV

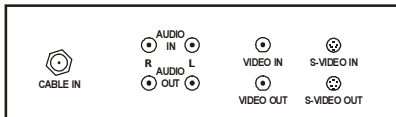

USING THE REMOTE CONTROL

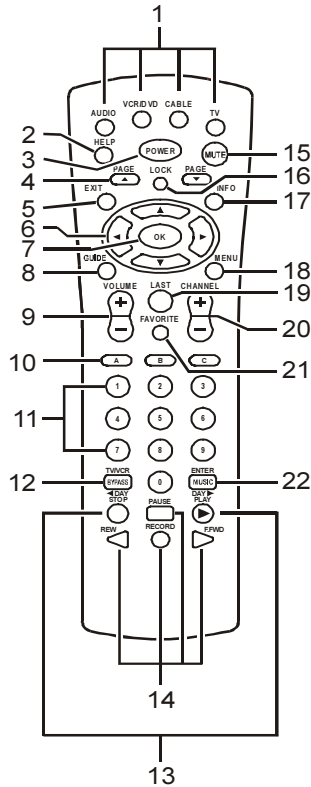

Use the remote control to operate the DCT2500, TV, and VCR.

Your remote control may be different from the one illustrated here. The remote control must be programmed for use. If your service provider has not programmed your remote control, refer to the remote control instruction guide supplied by your service provider.

USING THE REMOTE CONTROL

Key	Item	Description
1	AUDIO, VCR, CABLE, or TV	Selects the desired device to control (the selected mode remains active until you press another key)
2	HELP	Displays the help screen
3	POWER	Turns the selected home entertainment component on or off
4	PAGE ▲ or PAGE▼	Pages through menu screens and electronic program guide (EPG)
5	EXIT	Exits menus and EPG
6		Moves cursor around the EPG and menu screens
7	OK/SELECT	Selects menu options and Pay-Per-View events, or tunes programs from the EPG (your remote control may only have OK; it performs the same functions)
8	GUIDE	Displays the EPG

USING THE REMOTE CONTROL

Key	Item	Description
9	VOLUME + or VOLUME -	Increases or decreases volume of the currently selected device
10	A, B, or C	Functionality is determined by your service provider
11	NUMBER KEYS	Directly selects a channel
12	TV/VCR BYPASS	When in CABLE mode, enables RF Bypass, if available. Bypass is optional.
13	◀ DAY DAY ▶	Use when operating the electronic program guide (moves EPG ahead or back 24 hours)
14	STOP, PAUSE, PLAY, REW, RECORD, F.FWD	Controls the VCR
15	MUTE	Toggles the sound on and off
16	LOCK/PPV	Limits viewing of selected programs, and accesses the Pay-Per-View menu (your remote control may only have LOCK; this key performs the same functions)

USING THE REMOTE CONTROL

Key	Item	Description
17	INFO	Displays the current channel and program information (not supported by all applications)
18	MENU	Displays the Main menu
19	LAST	Recalls the last channel or goes back one screen in the menu
20	CHANNEL + or CHANNEL -	Changes the channels up or down
21	FAVORITE	Displays preset favorite cable channels
22	ENTER/MUSIC	Displays digital music channel menus (on some TV models, press to enter channels)

USING THE REMOTE CONTROL



Installing Batteries

Before you can use the remote control, you must install two AA (1.5-volt) alkaline batteries:

- 1** Slide open the battery door on the back of the remote control.
- 2** Insert the batteries in the direction indicated on the inside of the battery compartment.

Batteries installed incorrectly can cause battery leakage and corrosion that will damage the remote control.

- 3** Slide the battery door closed until it snaps into place.

Point the remote control at the DCT2500, press CABLE, and then press POWER. If the DCT2500 does not turn on, check the orientation of the batteries or replace with new batteries.

Your remote control may be different from the one illustrated here. Refer to the remote control instruction guide for details on battery installation.

Turning Power On and Off

Press POWER on the front panel to turn the DCT2500 on or off. If using the remote control, be sure it is in cable mode by pressing CABLE, and then press POWER.

Changing Channels

You can change channels in two ways:

- Press CHANNEL ▲ or ▼ on the front panel of the DCT2500, or press CHANNEL + or - on the remote control to step through the channel selection.
- Enter the number of the channel you want to tune using the numeric keys on the remote control.

Adjusting the Volume

Press VOLUME + or - on the remote control to adjust the volume. When you adjust the volume, the volume scale is displayed on the screen. Press MUTE on the remote control to turn the sound off and on again.

For best audio quality, use the remote control to set the DCT2500 to approximately $\frac{3}{4}$ of the maximum volume level and then adjust the audio levels on the external devices, such as your TV.

Your VCR's audio outputs are not affected by adjustments to the volume.

Electronic Program Guide

The electronic program guide (EPG) displays information about TV programs and enables you to access features such as Parental Control or Pay-Per-View. EPGs can vary in look and feel with each service provider. Reference the EPG instruction manual for detailed instructions.

Audio Output Modes

The DCT2500 includes utilities that enable you to select and adjust its DIGITAL AUDIO (coaxial or optical) or AUDIO OUT (RCA style) outputs. If your EPG takes advantage of these utilities, it provides menu choices to select and optimize the audio output and compression modes. For more information about audio output mode configuration, refer to your EPG user manual.

AUDIO/VIDEO CONNECTIONS



NOTE

It is important to remember not to place anything on top of the DCT2500 and to provide for adequate ventilation to prevent overheating.

Before you begin to hookup your DCT2500, review the following:

- For basic cable connections, use 75-ohm coaxial cables equipped with F-type connectors. You can find coaxial cables in your local electronics store.
- For audio or video outputs, use cables equipped with RCA-type connectors.
- For the digital audio optical output, use a Toslink cable.
- Disconnect power from the DCT2500 before connecting or changing cable connections.
- **Do not** place anything on top of the DCT2500, especially other home video components.

CONNECTING YOUR DCT2500

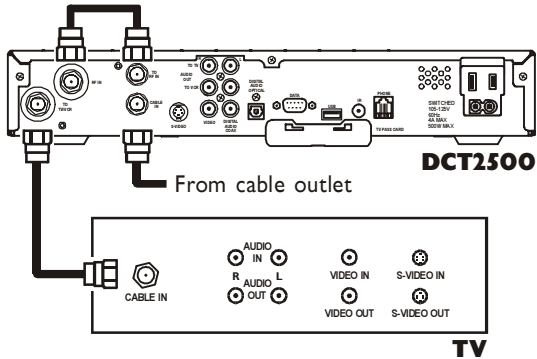

Standard TV Cabling

Use 75-ohm coaxial cables to connect your DCT2500 to a TV. This is the most common cable connection, and it provides all of the basic features of the DCT2500.

If you are using a diagram that connects the coaxial TO TV/VCR connector on the DCT2500 to the coaxial CABLE IN connector on the TV, you must tune your TV to channel 3 or 4.

The illustrated connections will not provide stereo audio. Connect the DCT2500 to the TV using standard RCA audio cables (left and right) to receive stereo audio on all channels, when available.

CONNECTING YOUR DCT2500

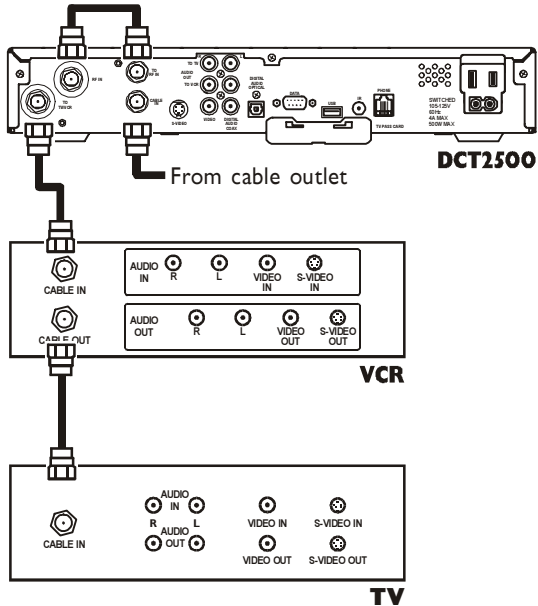

Standard VCR Cabling

To connect your VCR, you will need 75-ohm coaxial cables. The illustrated VCR connection enables you to record the program you are watching, including Pay-Per-View events. You can also view videotapes just as you do now.

The illustrated connections will not provide stereo audio. Connect the DCT2500 to the TV using standard RCA audio cables (left and right) to receive stereo audio on all channels, when available.

CONNECTING YOUR DCT2500

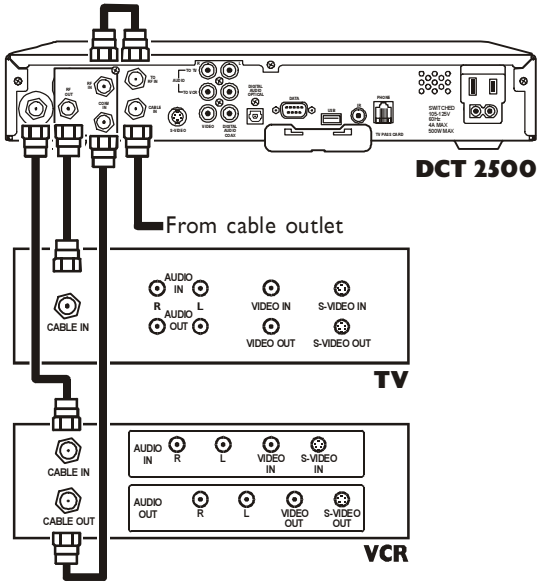

Cabling with RF Bypass

This cabling diagram illustrates the RF Bypass module installed on the DCT2500. The RF Bypass enables you to view an unscrambled analog channel on a TV while recording another channel through the DCT2500.

CONNECTING YOUR DCT2500

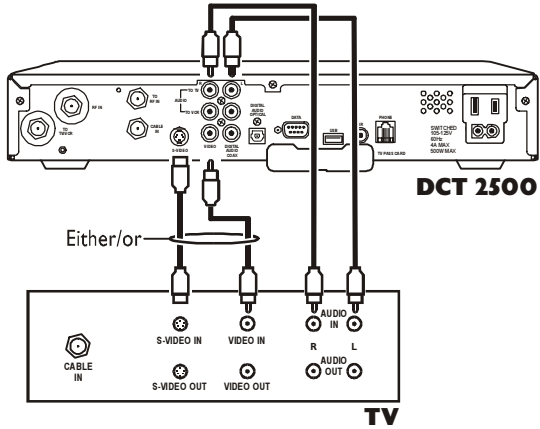

Composite Baseband and S-Video

Connecting the DCT2500 using the RCA-type baseband outputs enables you to experience stereo audio when available.

When connecting the video path, never connect baseband composite video and S-Video at the same time. Because some entertainment equipment will not support both video inputs simultaneously, use only one connection path.

CONNECTING YOUR DCT2500

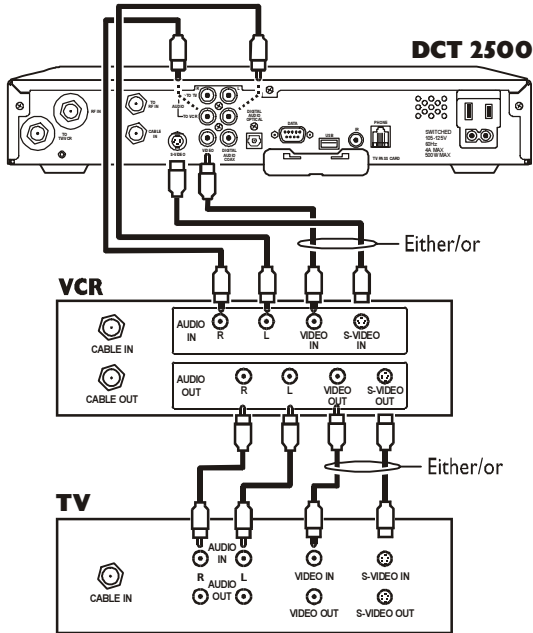

Composite VCR Cabling

This diagram illustrates how to connect the DCT2500 to a VCR using the audio connectors on the VCR.

When connecting the video path, never connect baseband composite video and S-Video at the same time. Because some entertainment equipment will not support both video inputs simultaneously, use only one connection path.

CONNECTING YOUR DCT2500

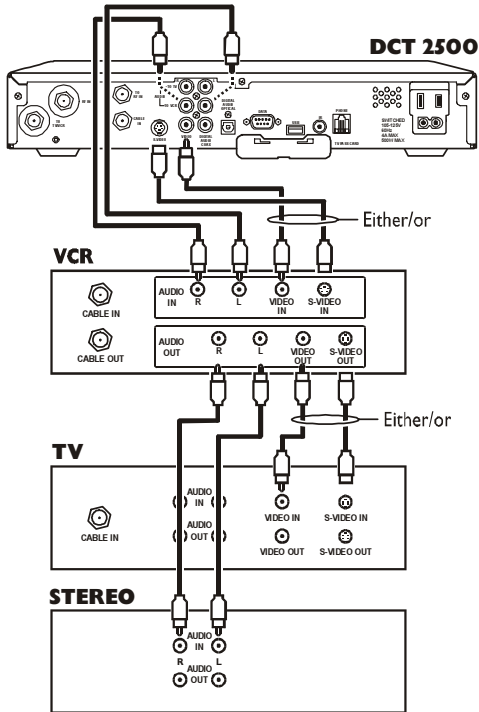

Stereo Cabling Diagram (VCR to Stereo)

This diagram illustrates how to connect the DCT2500 to a stereo using the audio connectors on the VCR. The VCR sound is played through the stereo.

When connecting the video path, never connect baseband composite video and S-Video at the same time. Because some entertainment equipment will not support both video inputs simultaneously, use only one connection path.

CONNECTING YOUR DCT2500

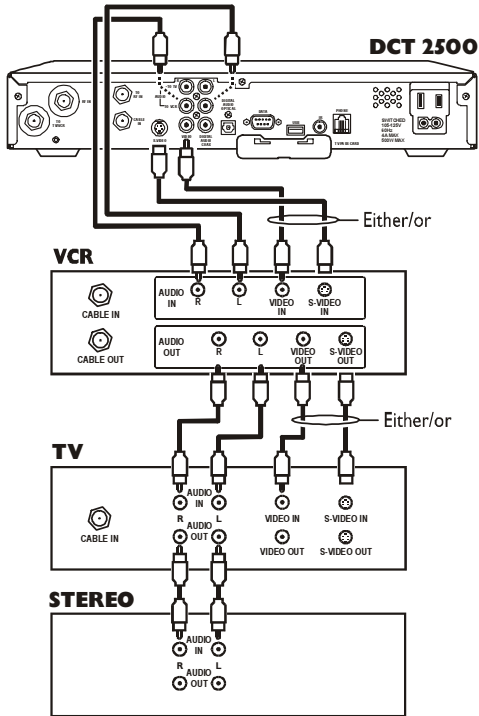

Stereo Cabling Diagram (TV to Stereo)

This configuration provides for the TV sound to play through the stereo.

When connecting the video path, never connect baseband composite video and S-Video at the same time. Because some entertainment equipment will not support both video inputs simultaneously, use only one connection path.

CONNECTING YOUR DCT2500

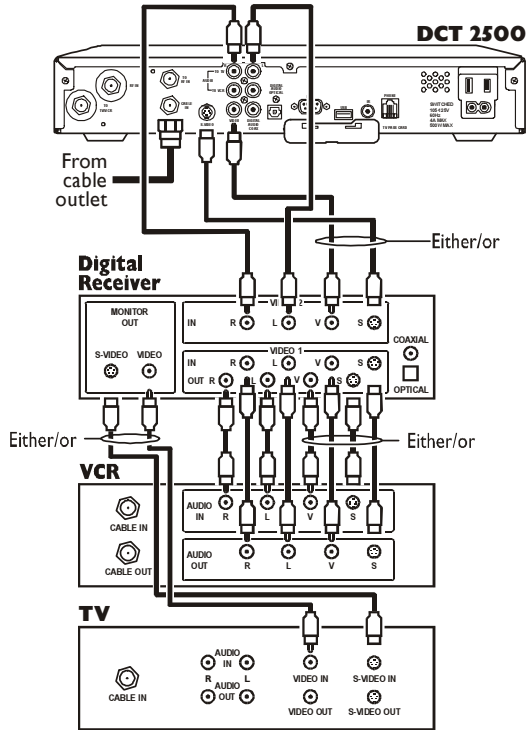

In this illustration the baseband connectors on the entertainment components are labeled R for right audio, L for left audio, V for video, and S for S-video.

Baseband Cabling Diagram

This diagram illustrates audio and video connections to a Dolby® Digital receiver. This configuration enables you to record on the VCR and playback with sound through the Dolby Digital receiver.

To playback Dolby Digital 5.1 sound through the Dolby Digital receiver, you must connect the DCT2500 to the receiver using the DIGITAL AUDIO COAX or DIGITAL AUDIO OPTICAL connections. The audio R and L connectors do not carry Dolby Digital 5.1. See the Dolby Digital Cabling Diagram for more information.

CONNECTING YOUR DCT2500

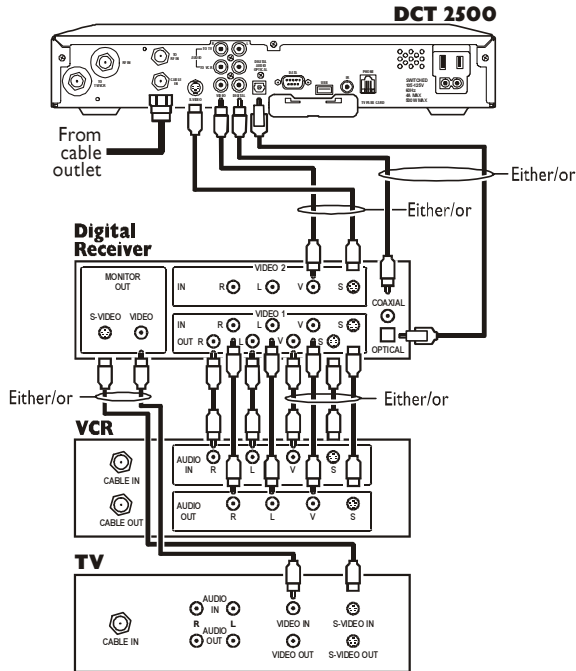

In this illustration the baseband connectors on the entertainment components are labeled R for right audio, L for left audio, V for video, and S for S-video.

Dolby Digital Cabling Diagram

This diagram illustrates audio and video connections to a Dolby Digital receiver. This configuration enables you to record on the VCR and playback with sound through the Dolby Digital receiver.

To playback Dolby Digital 5.1 sound through the Dolby Digital receiver, you must connect the DCT2500 to the receiver using the DIGITAL AUDIO COAX or DIGITAL AUDIO OPTICAL connections. The audio R and L connectors do not carry Dolby Digital 5.1.

TROUBLESHOOTING

Before calling your service provider, review the troubleshooting guide. This information is to help you quickly solve a problem. If your problem still exists, contact your service provider.

Problem	Possible Solution
No sound	<p>Press MUTE on the remote control to restore the volume level.</p> <p>Check that the stereo is set to the proper input source.</p> <p>Turn your VCR on.</p> <p>Make sure the TV or stereo volume is set to an appropriate level. For best audio level control, use the remote control to set the DCT2500 to approximately $\frac{3}{4}$ of the maximum volume level and then adjust the audio levels of the external devices.</p>
No picture	<p>Check to be sure that all cables are connected properly (hand-tighten if necessary).</p> <p>If connected through the baseband RCA video connection, make sure the cables are connected properly.</p> <p>If you are watching TV using your VCR, be sure your VCR is on.</p>
Picture or sound is noisy on one channel	<p>Reconnect the cable and hand-tighten if loose.</p>
Sound from only one stereo speaker	<p>Hand-tighten or reconnect the cables properly. Be sure wires are not frayed and plugs are not bent or broken.</p>

TROUBLESHOOTING

Problem	Possible Solution
No power	Reconnect the power cord. Be sure the DCT2500 is plugged into an outlet that is always live.
Remote control does not work	Press CABLE on the remote control to ensure the remote control is in cable mode. Change the batteries in your remote control according to the instructions in the section, "Installing Batteries." Be sure that nothing is on the DCT2500 or blocking a clear line of sight between it and the remote control.

Visit our website at:
www.motorola.com



504991-001
05-03

MGBI